

A

# SECTION STR

STR

## STARTING SYSTEM

C

### CONTENTS

D

E

|   |    |  |    |   |
|---|----|--|----|---|
| <b>BASIC INSPECTION</b> .....               | 2  | Symptom Table .....  | 12 | F |
| <b>DIAGNOSIS AND REPAIR WORK FLOW</b> ..... | 2  | <b>PRECAUTION</b> .....  | 13 |   |
| Work Flow (With GR8-1200 NI) .....          | 2  | <b>PRECAUTIONS</b> .....   | 13 | G |
| Work Flow (Without GR8-1200 NI) .....       | 5  | Precaution for Supplemental Restraint System (SRS) "AIR BAG" and "SEAT BELT PRE-TENSIONER" ..... | 13 | H |
| <b>SYSTEM DESCRIPTION</b> .....             | 7  | Precaution for Procedure without Cowl Top Cover...13   |    |   |
| <b>STARTING SYSTEM</b> .....                | 7  | Precautions For Xenon Headlamp Service .....   | 13 | I |
| System Diagram .....                        | 7  | <b>PREPARATION</b> .....   | 15 |   |
| System Description .....                    | 7  | <b>PREPARATION</b> .....   | 15 | J |
| Component Parts Location .....              | 8  | Special Service Tools .....  | 15 |   |
| Component Description .....                 | 8  | Commercial Service Tools .....   | 15 | K |
| <b>DTC/CIRCUIT DIAGNOSIS</b> .....          | 9  | <b>REMOVAL AND INSTALLATION</b> .....  | 16 |   |
| <b>B TERMINAL CIRCUIT</b> .....             | 9  | <b>STARTER MOTOR</b> .....   | 16 | L |
| Description .....                           | 9  | Exploded View .....  | 16 |   |
| Diagnosis Procedure .....                   | 9  | Removal and Installation .....   | 17 | M |
| <b>S CONNECTOR CIRCUIT</b> .....            | 10 | <b>SERVICE DATA AND SPECIFICATIONS (SDS)</b> .....   | 19 | N |
| Description .....                           | 10 | <b>SERVICE DATA AND SPECIFICATIONS (SDS)</b> .....   | 19 | O |
| Diagnosis Procedure .....                   | 10 | Starter Motor .....  | 19 | P |
| <b>STARTING SYSTEM</b> .....                | 11 |  |    |   |
| Wiring Diagram - STARTING SYSTEM - .....    | 11 |  |    |   |
| <b>SYMPTOM DIAGNOSIS</b> .....              | 12 |  |    |   |
| <b>STARTING SYSTEM</b> .....                | 12 |  |    |   |

## DIAGNOSIS AND REPAIR WORK FLOW

< BASIC INSPECTION >

---

### BASIC INSPECTION

#### DIAGNOSIS AND REPAIR WORK FLOW

Work Flow (With GR8-1200 NI)

*INFOID:000000008837696*

#### STARTING SYSTEM DIAGNOSIS WITH GR8-1200 NI

To test the starting system, use the following special service tool:

- GR8-1200 NI Multitasking battery and electrical diagnostic station

**NOTE:**

Refer to the diagnostic station Instruction Manual for proper starting system diagnosis procedures.

# DIAGNOSIS AND REPAIR WORK FLOW

< BASIC INSPECTION >

## OVERALL SEQUENCE

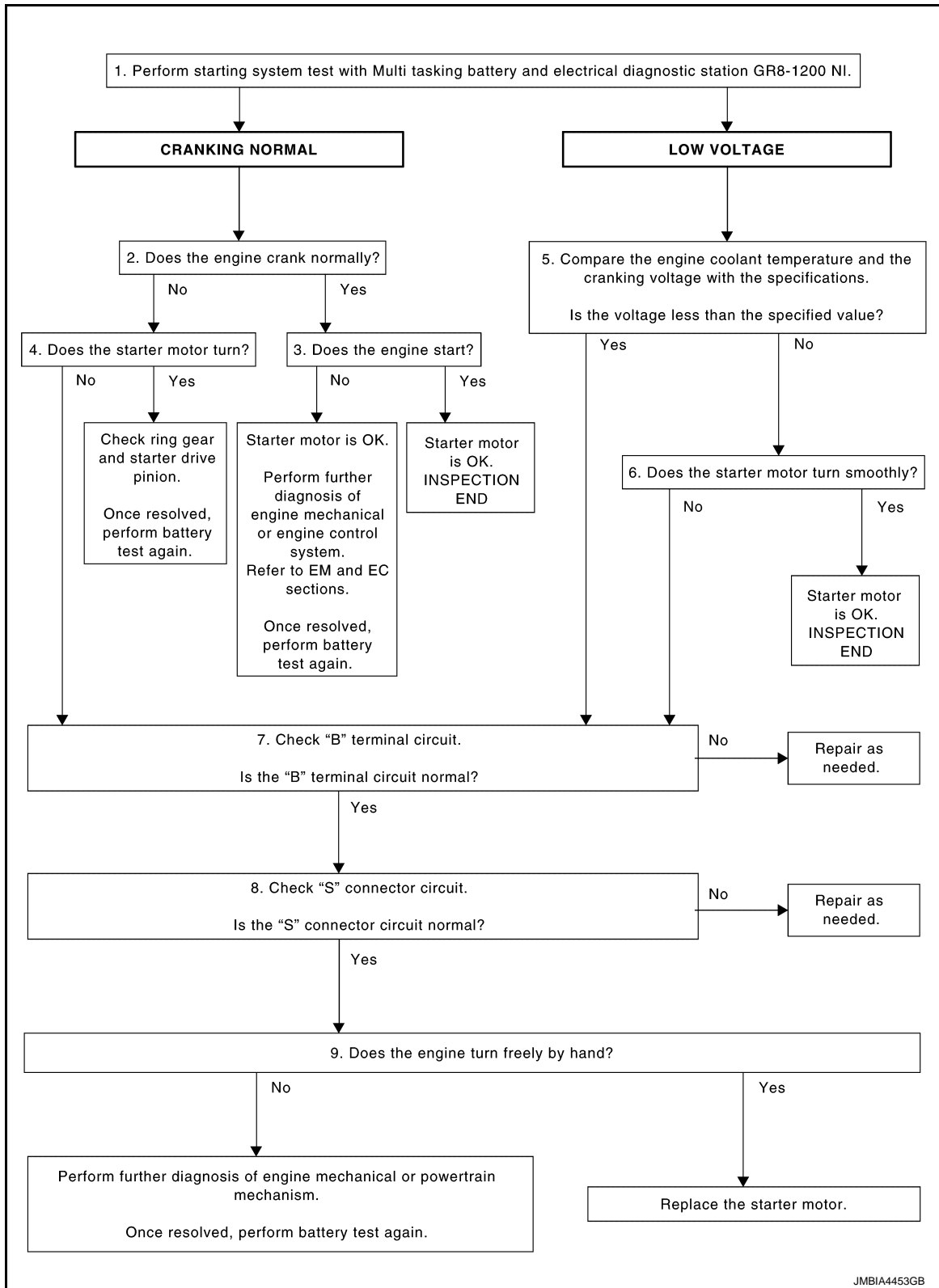

### DETAILED FLOW

#### NOTE:

To ensure a complete and thorough diagnosis, the battery, starter motor and alternator test segments must be done as a set from start to finish.

### 1. DIAGNOSIS WITH MULTITASKING BATTERY AND ELECTRICAL DIAGNOSTIC STATION GR8-1200 NI

A

STR

C

D

E

F

G

H

I

J

K

L

M

N

O

P

# DIAGNOSIS AND REPAIR WORK FLOW

## < BASIC INSPECTION >

Perform the starting system test with Multitasking battery and electrical diagnostic station GR8-1200 NI. For details and operating instructions, refer to diagnostic station Instruction Manual.

### Test result

CRANKING NORMAL>>GO TO 2.

LOW VOLTAGE>>GO TO 5.

CHARGE BATTERY>>Perform the slow battery charging procedure. (Initial rate of charge is 10A for 12 hours.) Perform battery test again. Refer to diagnostic station instruction manual.

REPLACE BATTERY>>Before replacing battery, clean the battery cable clamps and battery posts. Perform battery test again. Refer to diagnostic station instruction manual. If second test result is "REPLACE BATTERY", then do so. Perform battery test again to confirm repair.

## 2. CRANKING CHECK

Check that the starter motor operates correctly.

### Does the engine crank normally?

YES >> GO TO 3.

NO >> GO TO 4.

## 3. ENGINE START CHECK

Check that the engine starts.

### Does the engine start?

YES >> Starter motor is OK. INSPECTION END

NO >> Perform further diagnosis of engine mechanical or engine control system. Refer EM and EC sections. Once resolved, perform battery test again.

## 4. STARTER MOTOR ACTIVATION

Check that the starter motor operates.

### Does the starter motor turn?

YES >> Check ring gear and starter motor drive pinion. Once resolved, perform battery test again.

NO >> GO TO 7.

## 5. COMPARISON BETWEEN ENGINE COOLANT AND CRANKING VOLTAGE

Compare the engine coolant temperature and the cranking voltage with the specifications.

### Minimum Specification of Cranking Voltage Referencing Coolant Temperature

| Engine coolant temperature [°C (°F)] | Voltage [V] |
|--------------------------------------|-------------|
| -30 to -20 (-22 to -4)               | 8.6         |
| -19 to -10 (-2 to 14)                | 9.1         |
| -9 to 0 (16 to 32)                   | 9.5         |
| More than 1 (More than 34)           | 9.9         |

### Is the voltage less than the specified value?

YES >> GO TO 7.

NO >> GO TO 6.

## 6. STARTER OPERATION

Check the starter operation status.

### Does the starter motor turn smoothly?

YES >> Starter motor is OK. INSPECTION END

NO >> GO TO 7.

## 7. "B" TERMINAL CIRCUIT INSPECTION

Check "B" terminal circuit. Refer to [STR-9. "Diagnosis Procedure"](#).

### Is "B" terminal circuit normal?

YES >> GO TO 8.

NO >> Repair as needed.

## 8. "S" CONNECTOR CIRCUIT INSPECTION

Check "S" connector circuit. Refer to [STR-10. "Diagnosis Procedure"](#).

# DIAGNOSIS AND REPAIR WORK FLOW

## < BASIC INSPECTION >

Is "S" connector circuit normal?

- YES >> GO TO 9.
- NO >> Repair as needed.

## 9. ENGINE ROTATION STATUS

Check that the engine can be rotated by hand.

Does the engine turn freely by hand?

- YES >> Replace starter motor. Refer to [STR-17. "Removal and Installation"](#).
- NO >> Perform further diagnosis of engine mechanical or powertrain mechanism. Once resolved, perform battery test again using Multitasking battery and electrical diagnostic station GR8-1200 NI. Refer to the diagnostic station Instruction Manual for proper testing procedures.

## Work Flow (Without GR8-1200 NI)

INFOID:0000000008837697

## OVERALL SEQUENCE

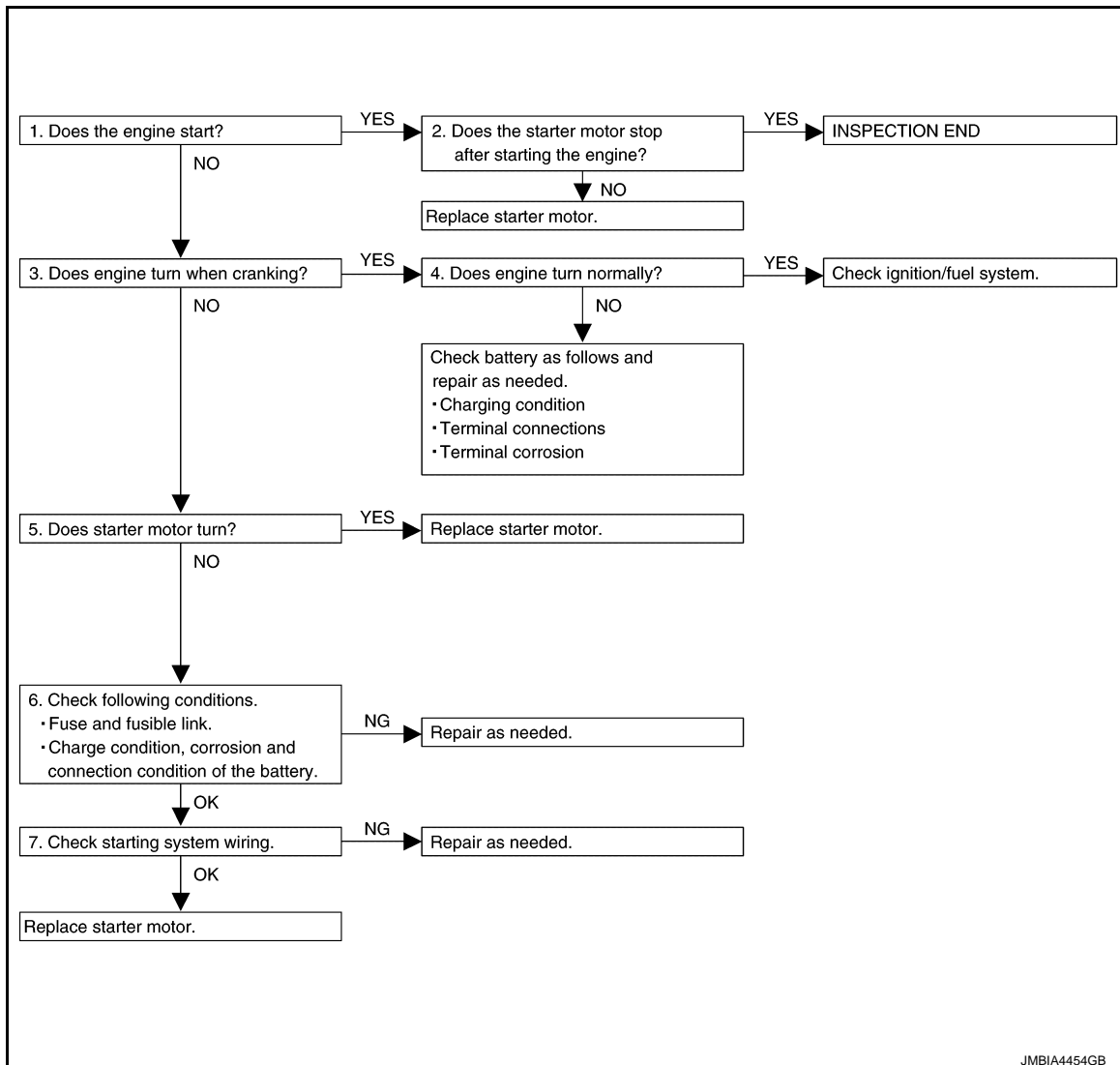

## DETAILED FLOW

### NOTE:

If any malfunction is found, immediately disconnect the battery cable from the negative terminal.

## 1. CHECK ENGINE START

Crank the engine and check that the engine starts.

Does the engine start?

- YES >> GO TO 2.

# DIAGNOSIS AND REPAIR WORK FLOW

## < BASIC INSPECTION >

---

NO >> GO TO 3.

### 2.CHECK THAT THE STARTER MOTOR STOPS

---

Check that the starter motor stops after starting the engine.

Does the starter motor stop?

YES >> INSPECTION END

NO >> Replace starter motor. Refer to [STR-17, "Removal and Installation"](#).

### 3.CHECK THAT THE ENGINE TURNS WHEN CRANKING

---

Check that the engine turns when cranking.

Does engine turn when cranking?

YES >> GO TO 4.

NO >> GO TO 5.

### 4.CHECK THE ENGINE SPEED WHEN CRANKING

---

Check that the engine speed is not low when cranking.

Does engine turn normally?

YES >> Check ignition/fuel system.

NO >> Check charge condition, corrosion and connection condition of the battery. Refer to [PG-3, "Work Flow"](#).

### 5.CHECK STARTER MOTOR ACTIVATION

---

Check that the starter motor runs at cranking.

Does starter motor turn?

YES >> Replace starter motor. Refer to [STR-17, "Removal and Installation"](#).

NO >> GO TO 6.

### 6.CHECK POWER SUPPLY CIRCUIT

---

Check the following conditions.

- Fuse and fusible link
- Charge condition, corrosion and connection condition of the battery. Refer to [PG-3, "Work Flow"](#).

Are these inspection results normal?

YES >> GO TO 7.

NO >> Repair as needed.

### 7.CHECK STARTING SYSTEM WIRING

---

Check the following.

- "B" terminal circuit. Refer to [STR-9, "Diagnosis Procedure"](#).
- "S" connector circuit. Refer to [STR-10, "Diagnosis Procedure"](#).

Are these inspection results normal?

YES >> Replace starter motor. Refer to [STR-17, "Removal and Installation"](#).

NO >> Repair as needed.

# STARTING SYSTEM

< SYSTEM DESCRIPTION >

## SYSTEM DESCRIPTION

### STARTING SYSTEM

#### System Diagram

INFOID:000000008293306

A

STR

C

D

E

F

G

H

I

J

K

L

M

N

O

P

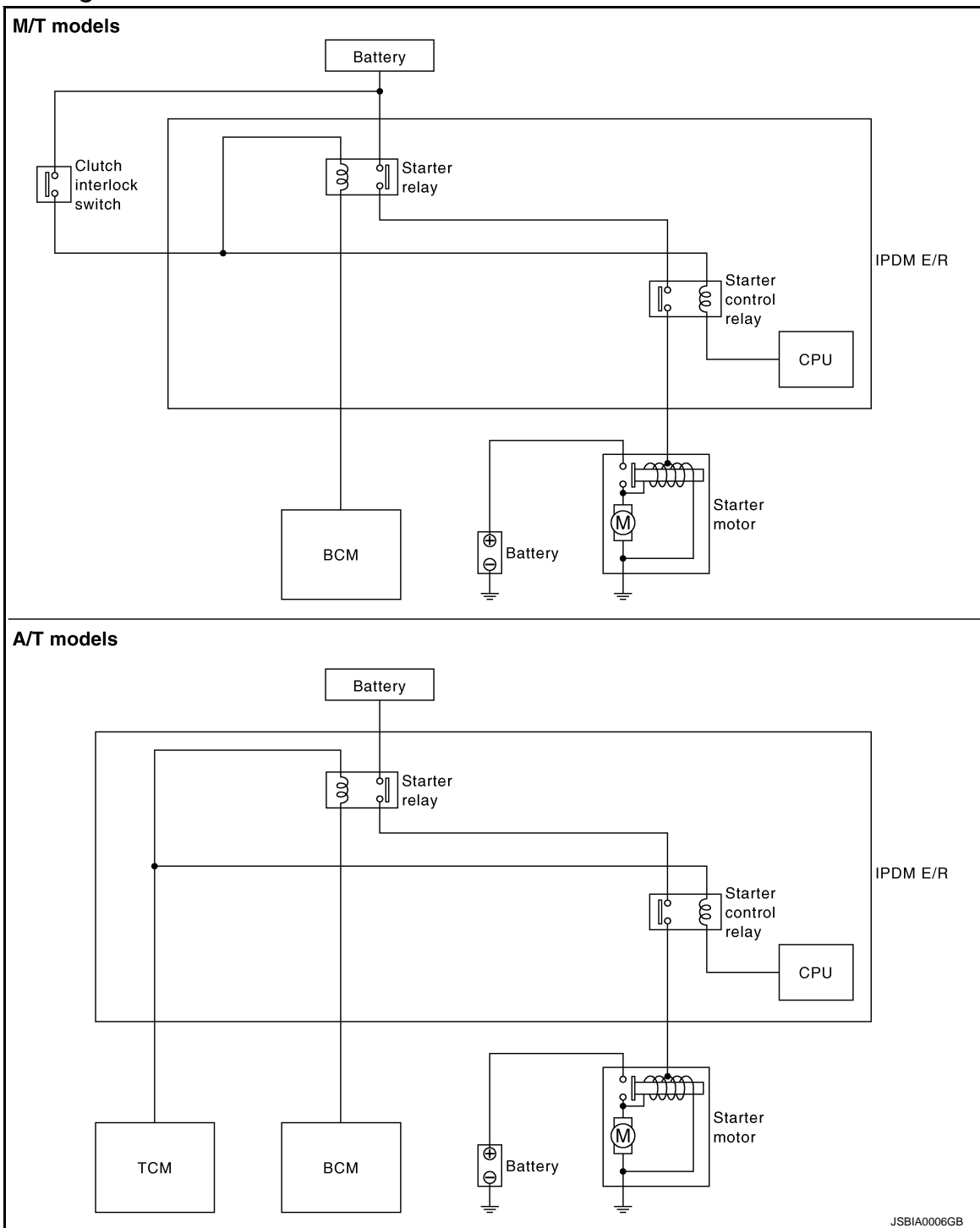

JSBIA0006GB

#### System Description

INFOID:000000008293307

The starter motor plunger closes and provides a closed circuit between the battery and starter motor. The starter motor is grounded to the engine block. With power and ground supplied, cranking occurs and the engine starts.

# STARTING SYSTEM

< SYSTEM DESCRIPTION >

## Component Parts Location

INFOID:000000008293308

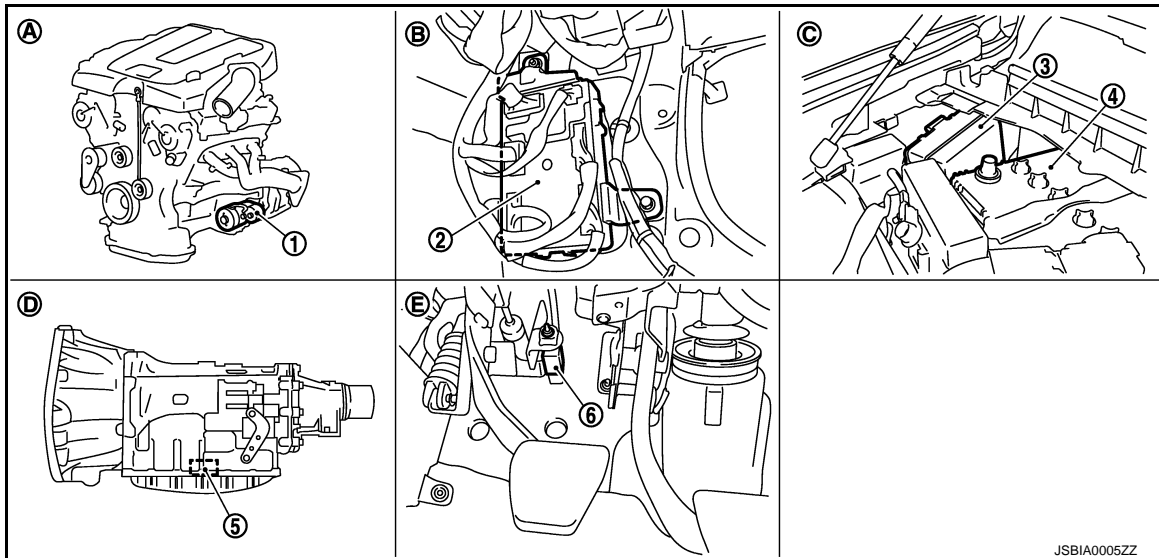

- |                                   |                                     |                                |
|-----------------------------------|-------------------------------------|--------------------------------|
| 1. Starter motor                  | 2. BCM                              | 3. IPDM E/R                    |
| 4. Battery                        | 5. TCM                              | 6. Clutch interlock switch     |
| A. Engine                         | B. Dash side lower (passenger side) | C. Engine room dash panel (RH) |
| D. Inside of A/T (built into A/T) | E. Clutch pedal                     |                                |

## Component Description

INFOID:000000008293309

| Component part          | Description  |
|-------------------------|--|
| TCM                     | TCM supplies power to the starter relay and starter control relay inside IPDM E/R when the selector lever is shifted to the P or N position.                           |
| Clutch interlock switch | The switch turns ON and electric power is supplied to the starter relay and starter control relay inside IPDM E/R when the clutch pedal is depressed.                  |
| BCM                     | BCM controls the starter relay inside IPDM E/R.  |
| IPDM E/R                | CPU inside IPDM E/R controls the starter control relay.  |
| Starter motor           | The starter motor plunger closes and the motor is supplied with battery power, which in turn cranks the engine, when the "S" terminal is supplied with electric power. |



# B TERMINAL CIRCUIT

< DTC/CIRCUIT DIAGNOSIS >

## DTC/CIRCUIT DIAGNOSIS

### B TERMINAL CIRCUIT

#### Description

INFOID:000000008293310

STR

The "B" terminal is constantly supplied with battery power.

#### Diagnosis Procedure

INFOID:000000008293311

#### CAUTION:

Perform diagnosis under the condition that engine cannot start by the following procedure.

1. Remove fuel pump fuse.
2. Crank or start the engine (where possible) until the fuel pressure is released.

#### 1. CHECK "B" TERMINAL CIRCUIT

1. Turn ignition switch OFF.
2. Check that starter motor "B" terminal connection is clean and tight.
3. Check voltage between starter motor "B" terminal and ground.

| Terminals                  |          |        | Voltage (Approx.) |
|----------------------------|----------|--------|-------------------|
| (+)                        | (-)      |        |                   |
| Starter motor "B" terminal | Terminal |        | Battery voltage   |
| E204                       | 2        |        |                   |
|                            |          | Ground |                   |

Is the inspection result normal?

YES >> GO TO 2.

NO >> Check harness between battery and starter motor for open circuit.

#### 2. CHECK BATTERY CABLE CONNECTION STATUS (VOLTAGE DROP TEST)

1. Shift A/T selector lever to "P" or "N" position. (A/T models)  
Keep depressing clutch pedal fully. (M/T models)
2. Check voltage between battery positive terminal and starter motor "B" terminal.

| Terminals                 |                            |          | Condition                                     | Voltage (Approx.) |
|---------------------------|----------------------------|----------|---|-------------------|
| (+)                       | (-)                        |          |   |                   |
|                           | Starter motor "B" terminal | Terminal | When the ignition switch is in START position | Less than 0.5 V   |
| Battery positive terminal | E204                       | 2        |   |                   |

Is the inspection result normal?

YES >> GO TO 3.

NO >> Check harness between the battery and the starter motor for poor continuity.

#### 3. CHECK GROUND CIRCUIT STATUS (VOLTAGE DROP TEST)

1. Shift A/T selector lever to "P" or "N" position. (A/T models)  
Keep depressing clutch pedal fully. (M/T models)
2. Check voltage between starter motor case and battery negative terminal.

| Terminals          |                           | Condition                                     | Voltage (Approx.) |
|--------------------|---------------------------|---|-------------------|
| (+)                | (-)                       |   |                   |
| Starter motor case | Battery negative terminal | When the ignition switch is in START position | Less than 0.2 V   |

Is the inspection result normal?

YES >> "B" terminal circuit is OK. Further inspection is necessary. Refer to [STR-2, "Work Flow \(With GR8-1200 NI\)"](#) or [STR-5, "Work Flow \(Without GR8-1200 NI\)"](#).

NO >> Check the starter motor case and ground for poor continuity.

# S CONNECTOR CIRCUIT

< DTC/CIRCUIT DIAGNOSIS >

## S CONNECTOR CIRCUIT

### Description

INFOID:000000008293312

The starter motor magnetic switch is supplied with power when the ignition switch is turned to the START position while the selector lever is in the P or N position for A/T models or the clutch pedal is depressed for M/T models.

### Diagnosis Procedure

INFOID:000000008293313

#### CAUTION:

Perform diagnosis under the condition that engine cannot start by the following procedure.

1. Remove fuel pump fuse.
2. Crank or start the engine (where possible) until the fuel pressure is released.

#### 1. CHECK "S" CONNECTOR CIRCUIT

1. Turn ignition switch OFF.
2. Disconnect starter motor connector.
3. Shift A/T selector lever to "P" or "N" position. (A/T models)  
Keep depressing clutch pedal fully. (M/T models)
4. Check voltage between starter motor harness connector and ground.

| Terminals                       |          | Condition                                     | Voltage (Approx.) |
|---------------------------------|----------|---|-------------------|
| (+)                             | (-)      |   |                   |
| Starter motor harness connector | Terminal |   |                   |
| F52                             | 1        | When the ignition switch is in START position | Battery voltage   |

#### Is the inspection result normal?

YES >> "S" connector circuit is OK. Further inspection is necessary. Refer to [STR-2, "Work Flow \(With GR8-1200 NI\)"](#) or [STR-5, "Work Flow \(Without GR8-1200 NI\)"](#).

NO >> GO TO 2.

#### 2. CHECK CONNECTOR

1. Turn ignition switch OFF.
2. Check the following terminals and connectors for damage, bend and loose connection.
  - Harness connector F1
  - Harness connector E3

#### Is the inspection result normal?

YES >> GO TO 3.

NO >> Repair the terminal and connector.

#### 3. CHECK HARNESS CONTINUITY (OPEN CIRCUIT)

1. Disconnect IPDM E/R connector.
2. Check continuity between starter motor harness connector and IPDM E/R harness connector.

| Starter motor harness connector |              | IPDM E/R harness connector |              | Continuity |
|---------------------------------|--------------|----------------------------|--------------|------------|
| Connector No.                   | Terminal No. | Connector No.              | Terminal No. |            |
| F52                             | 1            | E7                         | 80           | Existed    |

#### Is the inspection result normal?

YES >> Further inspection is necessary. Refer to [STR-2, "Work Flow \(With GR8-1200 NI\)"](#) or [STR-5, "Work Flow \(Without GR8-1200 NI\)"](#).

NO >> Repair the harness.

# STARTING SYSTEM

< DTC/CIRCUIT DIAGNOSIS >

## STARTING SYSTEM

### Wiring Diagram - STARTING SYSTEM -

INFOID:000000008293314

For connector terminal arrangements, harness layouts, and alphabets in a  (option abbreviation; if not described in wiring diagram), refer to [GI-12, "Connector Information"](#).

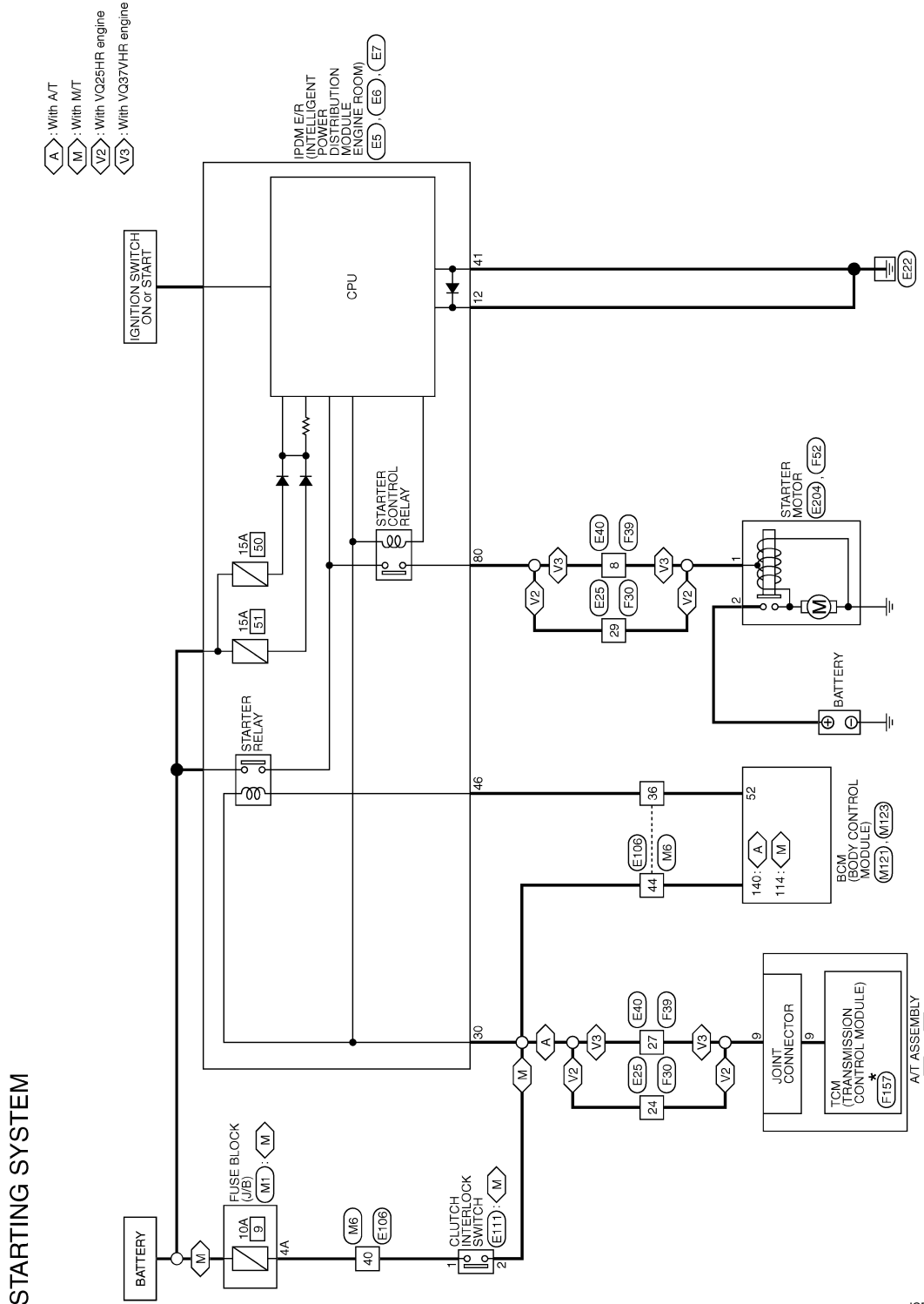

# STARTING SYSTEM

< SYMPTOM DIAGNOSIS >

## SYMPTOM DIAGNOSIS

### STARTING SYSTEM

#### Symptom Table

INFOID:000000008293315

| Symptom                       | Reference  |
|-------------------------------|--|
| No normal cranking            | Refer to <a href="#">STR-2. "Work Flow (With GR8-1200 NI)"</a> or <a href="#">STR-5. "Work Flow (Without GR8-1200 NI)"</a> . |
| Starter motor does not rotate |  |

# PRECAUTIONS

< PRECAUTION >

## PRECAUTION

### PRECAUTIONS

#### Precaution for Supplemental Restraint System (SRS) "AIR BAG" and "SEAT BELT PRE-TENSIONER"

INFOID:000000008293316

The Supplemental Restraint System such as "AIR BAG" and "SEAT BELT PRE-TENSIONER", used along with a front seat belt, helps to reduce the risk or severity of injury to the driver and front passenger for certain types of collision. This system includes seat belt switch inputs and dual stage front air bag modules. The SRS system uses the seat belt switches to determine the front air bag deployment, and may only deploy one front air bag, depending on the severity of a collision and whether the front occupants are belted or unbelted. Information necessary to service the system safely is included in the "SRS AIR BAG" and "SEAT BELT" of this Service Manual.

#### **WARNING:**

Always observe the following items for preventing accidental activation.

- To avoid rendering the SRS inoperative, which could increase the risk of personal injury or death in the event of a collision that would result in air bag inflation, all maintenance must be performed by an authorized NISSAN/INFINITI dealer.
- Improper maintenance, including incorrect removal and installation of the SRS, can lead to personal injury caused by unintentional activation of the system. For removal of Spiral Cable and Air Bag Module, see "SRS AIR BAG".
- Never use electrical test equipment on any circuit related to the SRS unless instructed to in this Service Manual. SRS wiring harnesses can be identified by yellow and/or orange harnesses or harness connectors.

#### PRECAUTIONS WHEN USING POWER TOOLS (AIR OR ELECTRIC) AND HAMMERS

#### **WARNING:**

Always observe the following items for preventing accidental activation.

- When working near the Air Bag Diagnosis Sensor Unit or other Air Bag System sensors with the ignition ON or engine running, never use air or electric power tools or strike near the sensor(s) with a hammer. Heavy vibration could activate the sensor(s) and deploy the air bag(s), possibly causing serious injury.
- When using air or electric power tools or hammers, always switch the ignition OFF, disconnect the battery, and wait at least 3 minutes before performing any service.

#### Precaution for Procedure without Cowl Top Cover

INFOID:000000008293317

When performing the procedure after removing cowl top cover, cover the lower end of windshield with urethane, etc to prevent damage to windshield.

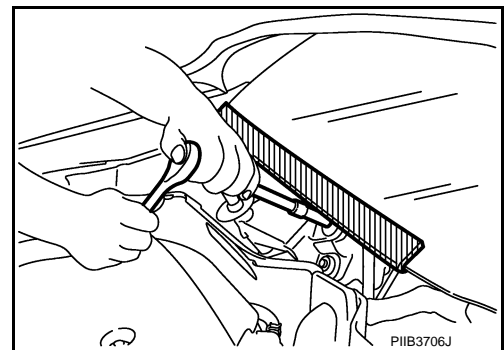

#### Precautions For Xenon Headlamp Service

INFOID:000000008293318

#### **WARNING:**

Comply with the following warnings to prevent any serious accident.

- Disconnect the battery cable (negative terminal) or the power supply fuse before installing, removing, or touching the xenon headlamp (bulb included). The xenon headlamp contains high-voltage generated parts.
- Never work with wet hands.
- Check the xenon headlamp ON-OFF status after assembling it to the vehicle. Never turn the xenon headlamp ON in other conditions. Connect the power supply to the vehicle-side connector.

A  
STR  
C  
D  
E  
F  
G  
H  
I  
J  
K  
L  
M  
N  
O  
P

## PRECAUTIONS

< PRECAUTION >

---

(Turning it ON outside the lamp case may cause fire or visual impairments.)

- Never touch the bulb glass immediately after turning it OFF. It is extremely hot.

**CAUTION:**

Comply with the following cautions to prevent any error and malfunction.

- Install the xenon bulb securely. (Insufficient bulb socket installation may melt the bulb, the connector, the housing, etc. by high-voltage leakage or corona discharge.)
- Never perform HID circuit inspection with a tester.
- Never touch the xenon bulb glass with hands. Never put oil and grease on it.
- Dispose of the used xenon bulb after packing it in thick vinyl without breaking it.
- Never wipe out dirt and contamination with organic solvent (thinner, gasoline, etc.).

# PREPARATION

< PREPARATION >

## PREPARATION

### PREPARATION

#### Special Service Tools

INFOID:000000008837699

A

STR

| Tool number<br>(Kent-Moore No.)<br>Tool name   | Description  |
|--|--|
| <p>—<br/>(—) Model GR8-1200 NI<br/>Multitasking battery and electrical diagnostic station</p>  <p style="text-align: right; font-size: small;">AWIA1239ZZ</p> | <p>Tests batteries, starting and charging systems and charges batteries.<br/>For operating instructions, refer to diagnostic station instruction manual.</p> |

C

D

E

#### Commercial Service Tools

INFOID:000000008293320

| Tool name  | Description                             |
|--|---|
| <p>Power tool</p>  <p style="text-align: right; font-size: small;">PIIB1407E</p> | <p>Loosening bolts, nuts and screws</p> |

F

G

H

I

J

K

L

M

N

O

P

# STARTER MOTOR

< REMOVAL AND INSTALLATION >

## REMOVAL AND INSTALLATION

### STARTER MOTOR

Exploded View

INFOID:00000000829321

#### REMOVAL

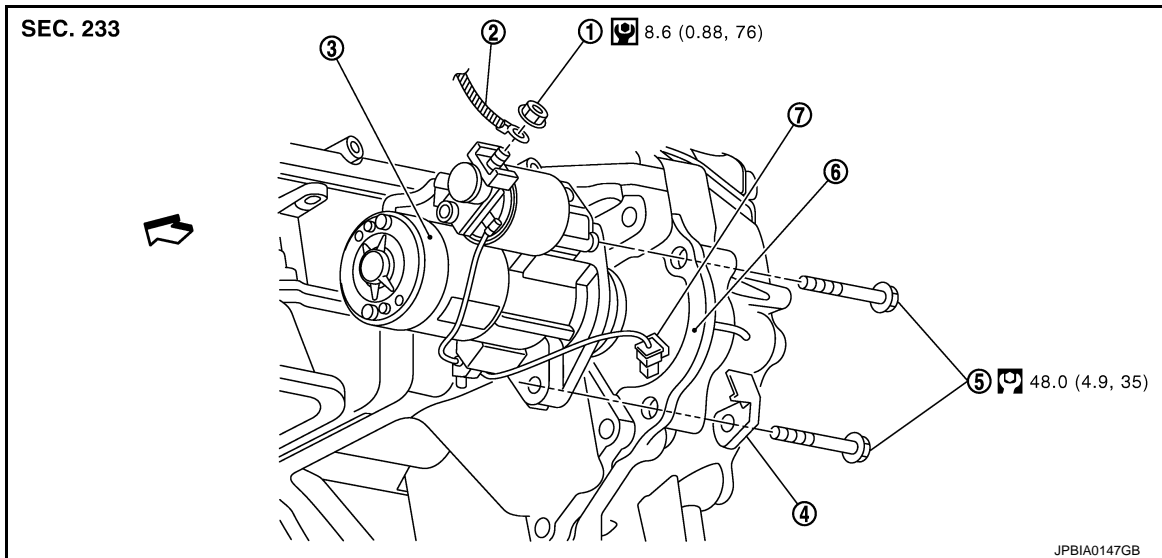

- |                         |                                |   |
|-------------------------|--------------------------------|---|
| 1. "B" terminal nut     | 2. "B" terminal harness        | 3. Starter motor  |
| 4. Harness clip bracket | 5. Starter motor mounting bolt | 6. Converter housing (A/T models)<br>Transmission case (M/T models) |
| 7. "S" connector        |                                |   |

↔ : Vehicle front

Refer to [GI-4, "Components"](#) for symbols in the figure.

#### DISASSEMBLY

Type: S114-932



# STARTER MOTOR

## < REMOVAL AND INSTALLATION >

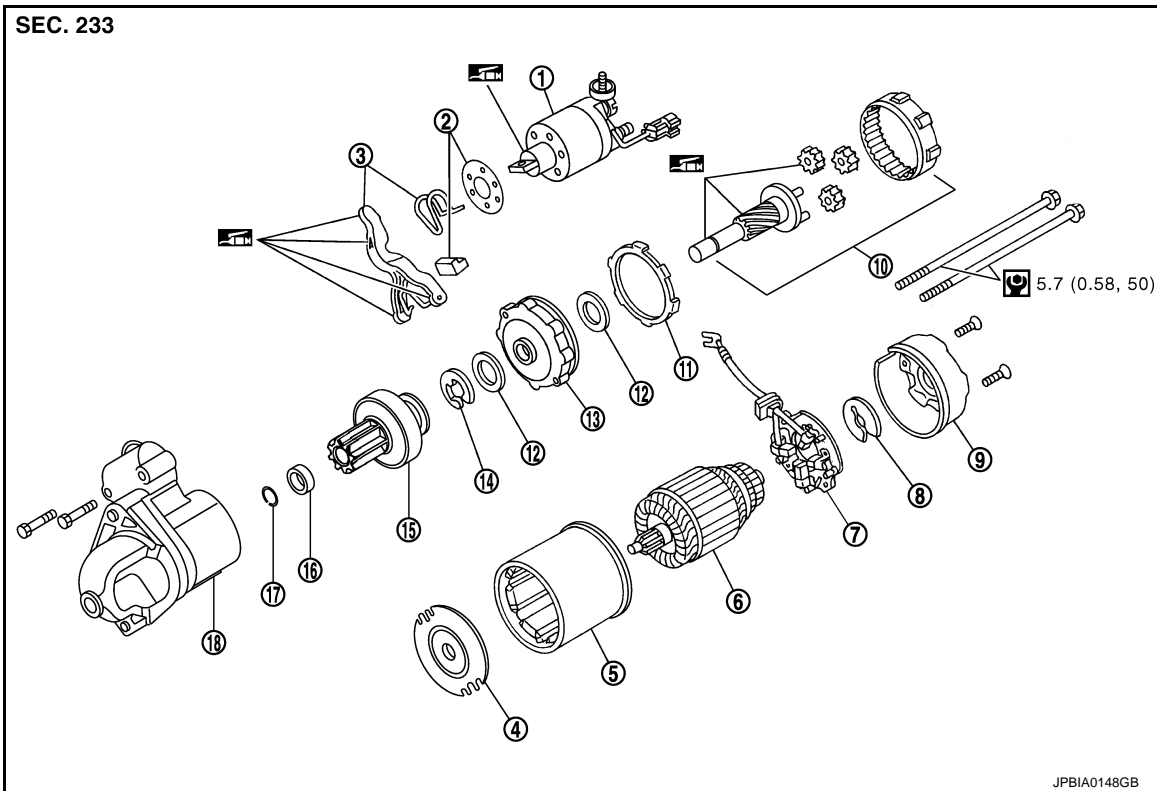

- |                             |                         |                        |
|-----------------------------|-------------------------|------------------------|
| 1. Magnetic switch assembly | 2. Dust cover kit       | 3. Shift lever set     |
| 4. Center bracket (A)       | 5. Yoke assembly        | 6. Armature assembly   |
| 7. Brush holder assembly    | 8. Thrust washer        | 9. Rear cover assembly |
| 10. Shaft gear assembly     | 11. Packing             | 12. Thrust washer      |
| 13. Center bracket (P)      | 14. E-ring              | 15. Pinion assembly    |
| 16. Pinion stopper          | 17. Pinion stopper clip | 18. Gear case assembly |

 : High-temperature grease point

Refer to [GI-4, "Components"](#) for symbols not described on the above.

## Removal and Installation

INFOID:000000008293322

### REMOVAL

1. Disconnect the battery cable from the negative terminal.
2. Remove engine undercover, using power tools.
3. Remove road wheel and tire (Front LH), using power tools.
4. Disconnect steering lower joint (1), then remove it. Refer to [ST-25, "Exploded View"](#).
5. Remove engine mounting insulator (LH) mounting nut (Lower). Refer to [EM-212, "2WD : Exploded View"](#).
6. Jack up the engine front side to create clearance for removing starter motor.
7. Remove "B" terminal nut (A).

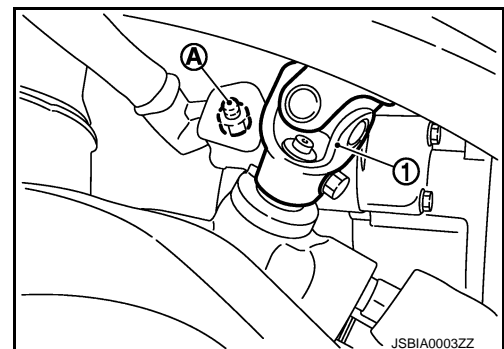

# STARTER MOTOR

## < REMOVAL AND INSTALLATION >

8. Disconnect "S" connector (A).

⇐ : Vehicle front

9. Remove starter motor mounting bolts (B), using power tools.

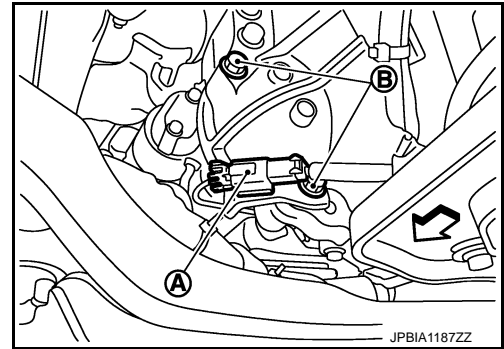

10. Remove starter motor (1) from the side of the vehicle.

⇐ : Vehicle front

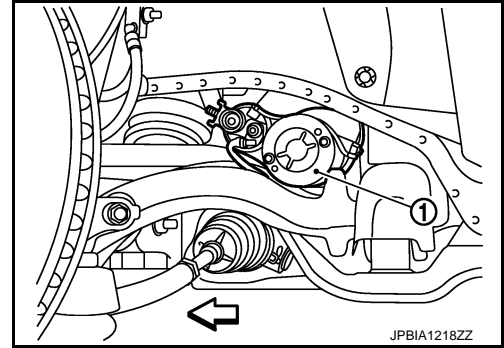

## INSTALLATION

Install in the reverse order of removal.

### **CAUTION:**

**Be sure to tighten "B" terminal nut carefully.**

# SERVICE DATA AND SPECIFICATIONS (SDS)

< SERVICE DATA AND SPECIFICATIONS (SDS)

## SERVICE DATA AND SPECIFICATIONS (SDS)

SERVICE DATA AND SPECIFICATIONS (SDS)

Starter Motor

INFOID:000000008293324

A

STR

|                |                     |       |                 |
|----------------|---------------------|-------|-----------------|
| Type           | S114-932            |       |                 |
|                | HITACHI make        |       |                 |
|                | Reduction gear type |       |                 |
| System voltage | [V]                 | 12    |                 |
| No-load        | Terminal voltage    | [V]   | 11              |
|                | Current             | [A]   | Less than 110   |
|                | Revolution          | [rpm] | More than 2,700 |

C

D

E

F

G

H

I

J

K

L

M

N

O

P